

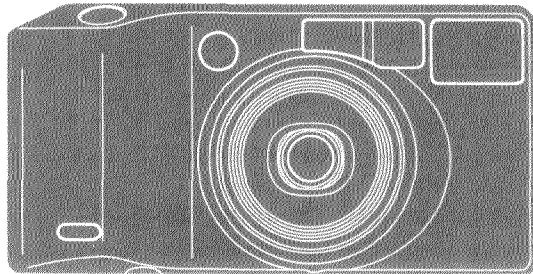

RIVA ZOOM 105EX FREEDOM ZOOM 105EX

INSTRUCTION MANUAL



Congratulations on your purchase of this Minolta camera. This manual gives you explanations for each function, plus all the information you'll need to understand and operate this camera properly.

To begin taking pictures in the easiest way possible, read **Getting Started**. Later, when you're ready to learn how to use the camera's other buttons and functions to improve your pictures, move along to **Advanced Operation**.

ATTACHING THE STRAP

Attach the strap as shown here.

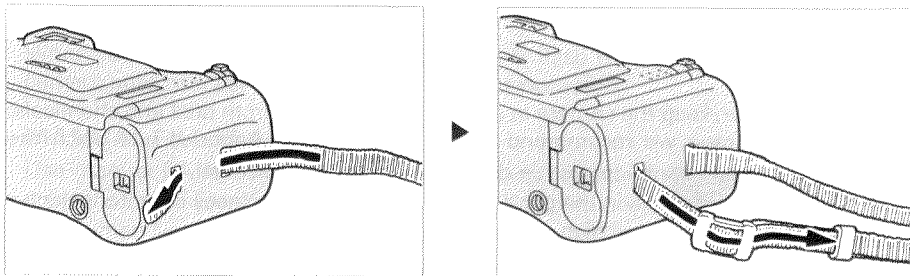

Minolta Camera Co., Ltd.

Minolta GmbH

Minolta France S.A.

Minolta (UK) Limited

Minolta Austria Ges. m.b.H.

Minolta Camera Benelux B.V.

Belgium Branch

Minolta (Schweiz) AG

Minolta Svenska AB

Finland Branch

Minolta Portugal Limitada

Minolta Corporation

Head Office

Los Angeles Branch

Minolta Canada Inc.

Head Office

Vancouver Branch

Minolta Hong Kong Limited

Minolta Singapore (Pte) Ltd.

3-13, 2-Chome, Azuchi-Machi, Chuo-Ku, Osaka 541, Japan

Kurl-Fischer-Strasse 50, D-22923 Ahrensburg, Germany

365, Route de Saint-Germain, 78420 Carrières-Sur-Seine, France

1-3 Tanners Drive, Blakelands North, Milton Keynes, MK14 5BU, England

Amalienstrasse 59-61, 1131 Wien, Austria

Zonnebaan 39, P.O. Box 1364 3600 Maarssenbroek, The Netherlands

Kontichsesteenweg 38, B-2630 Aartselaar, Belgium

Riedstrasse 6 8953 Dietlikon, Switzerland

Brännkyrkagatan 64, Box 17074, S-10462 Stockholm 17, Sweden

Niitykatu 6 PL 37 SF-02201 Espoo, Finland

Av. do Brasil 33 a, 1700 Lisbon, Portugal

101 Williams Drive, Ramsey, New Jersey 07446, U.S.A.

11150 Hope Street Cypress, CA 90630, U.S.A.

369 Britannia Road East, Mississauga, Ontario L4Z 2H5, Canada

106-3850 Jacobs Road, Richmond, B.C. V6V 1Y6, Canada

Room 208, 2/F, Eastern Center, 1065 King's Road, Quarry Bay, Hong Kong

10, Teban Gardens Crescent, Singapore 2260



© 1993 Minolta Camera Co., Ltd. under the Berne
Convention and Universal Copyright Convention

P9401-A5

9222-2419-11

Printed in Japan

STATEMENT OF FCC COMPLIANCE

This device complies with Part 15 of the FCC Rules. Operation is subject to the following two conditions: (1) This device may not cause harmful interference, and (2) this device must accept any interference received, including interference that may cause undesired operation. Changes or modifications not approved by the party responsible for compliance could void the user's authority to operate the equipment. This equipment has been tested and found to comply with the limits for a Class B digital device, pursuant to Part 15 of the FCC Rules. These limits are designed to provide reasonable protection against harmful interference in a residential installation. This equipment generates, uses and can radiate radio frequency energy and, if not installed and used in accordance with the instructions, may cause harmful interference to radio communications. However, there is no guarantee that interference will not occur in a particular installation. If this equipment does cause harmful interference to radio or television reception, which can be determined by turning the equipment off and on, the user is encouraged to try to correct the interference by one or more of the following measures:

- Reorient or relocate the receiving antenna.
- Increase the separation between the equipment and receiver.
- Connect the equipment into an outlet on a circuit different from that to which the receiver is connected.
- Consult the dealer or an experienced radio/TV technician for help.

STATEMENT OF DOC COMPLIANCE

This digital apparatus does not exceed the Class B limits for radio noise emissions from digital apparatus as set out in the Radio Interference Regulations of the Canadian Department of Communications.

NAMES OF PARTS

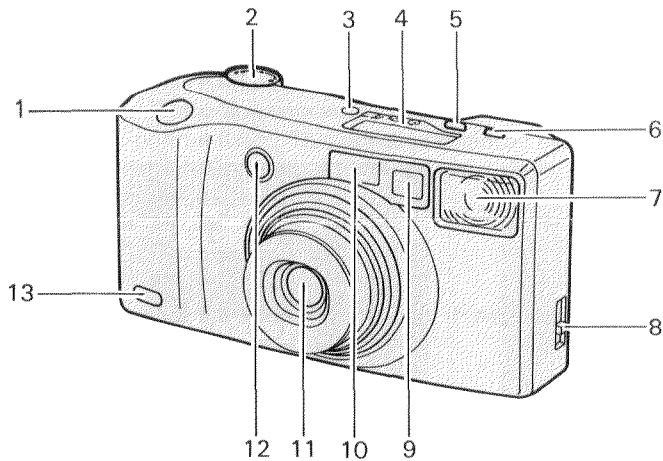

- 1. Shutter-release button
- 2. Zoom control
- 3. Operating-mode button
- 4. Data panel

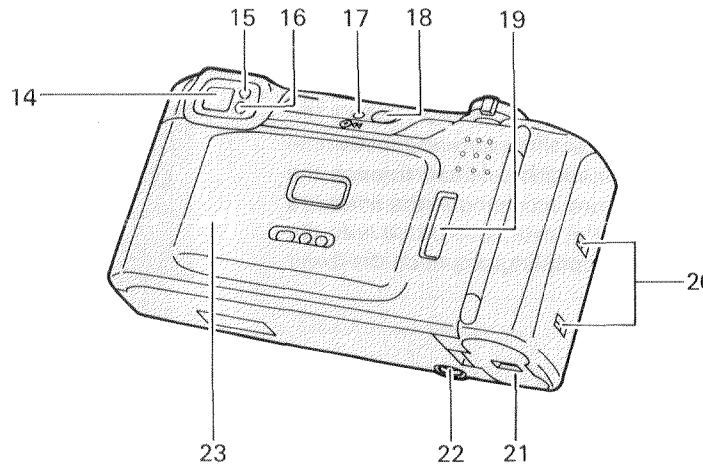

- 5. Red-eye-reduction button
- 6. Flash-mode button

- 7. Flash
- 8. Back-cover release
- 9. Viewfinder window*
- 10. Autofocus window*
- 11. Lens*
- 12. Red-eye-reduction lamp
- 13. Remote-control receiver
- 14. Viewfinder eyepiece*
- 15. Focus lamp
- 16. Flash lamp
- 17. Manual-rewind button
- 18. Power button
- 19. Film window
- 20. Strap eyelet
- 21. Battery cover
- 22. Tripod socket
- 23. Back cover

* Do not touch

VIEWFINDER

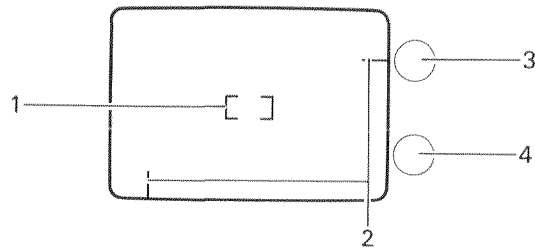

1. Focus frame

Camera focuses on the subjects within this frame.

2. Close-framing guides

When your subject is closer than 1.0m (3.3 ft.) at 38-60mm or 1.6m (5.2 ft.) at 65-105mm, the picture should be composed within this frame.

3. Focus lamp (green):

- Glowing: Focus is locked.
- Blinking slowly: Unable to focus.
- Blinking quickly: Subject too close.

4. Flash lamp (orange):

- Glowing: Flash will fire with next picture.
- Blinking slowly: Camera-shake warning.
- Blinking quickly: Flash is charging.

DATA PANEL

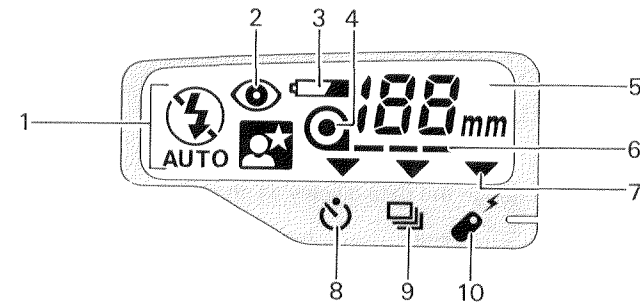

1. Flash-mode indicator

- : Auto-switchover flash
- : Manual fill-flash
- : Flash cancel
- : Night-portrait flash

2. Red-eye-reduction indicator

3. Low-battery symbol

- 4. Film-cartridge mark
- 5. Frame counter
- 6. Film-transport signals
- 7. Mode pointers
- 8. Self-timer mark
- 9. Continuous-drive mark
- 10. Remote-control mark

INSERTING BATTERIES

Your camera uses two 3-volt lithium batteries (CR123A/DL123A) that supplies power for all camera operations except the Data Back and Remote Control (both optional).

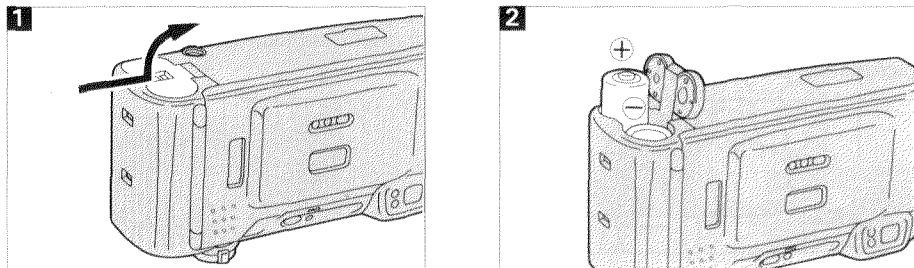

- 1 Open the battery cover by sliding the battery-cover lock in the direction indicated.
- 2 Insert the batteries as shown on the inside of the battery cover and snap the cover closed.

LOADING FILM

You should only use DX-coded, 35mm film between ISO 25 and 3200. We recommend ISO 400 speed or higher for telephoto photographs or pictures taken in low light.

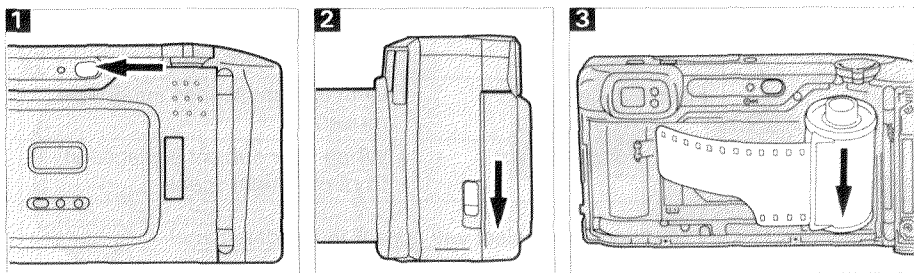

- 1 Turn the camera on and make sure 0 is displayed in the data panel.
- 2 Open the back cover by sliding the back-cover release down.
- 3 Place the film cartridge into the film chamber, bottom first as shown. Always load your film in the shade or away from direct sunlight. Polaroid instant 35mm films cannot be used.

LOW-BATTERY SYMBOL

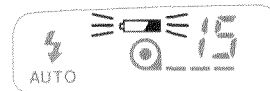

If the blinking low-battery symbol appears in the data panel along with the other indicators, you can still use the camera, but the batteries will have to be replaced soon.

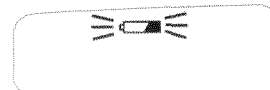

If the blinking low-battery symbol appears alone, replace the batteries.

AUTO POWER OFF

To save power, your camera automatically turns off if it is not operated for more than three minutes.

BATTERY CAUTIONS

- Read and follow all warnings and instructions supplied with the batteries.
- Keep batteries away from children.
- Do not attempt to disassemble, recharge, short out, or subject batteries to high temperatures or fire.
- Do not mix batteries of different ages or brands.

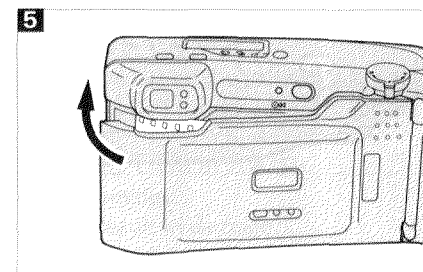
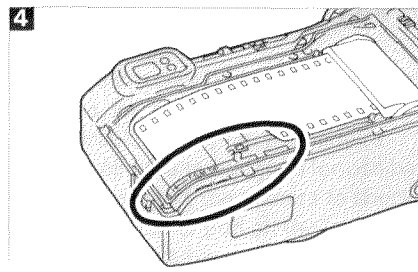

- 4 Lay the film flat between the guide rails and extend the film to the "FILM TIP" mark.

If the film extends too far, gently push the excess back into the cartridge.

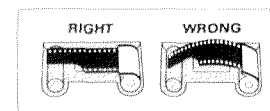

- 5 Snap the back cover closed.

The film automatically advances to the first frame and 1 appears in the data panel.



If 0 blinks in the data panel, the film was incorrectly loaded. Open the back cover and re-load the film.

BASIC OPERATION

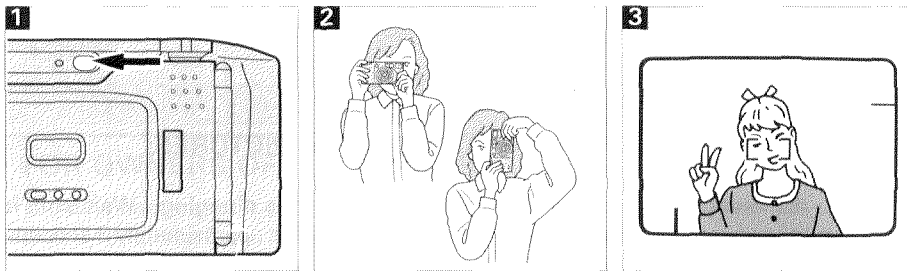

- 1** Press the power button to turn the camera on.
- 2** Hold the camera steady and make sure your fingers are not covering the flash. If you are taking a vertically-framed picture, turn the camera so the flash is on top as shown.
- 3** Center the focus frame on your subject.

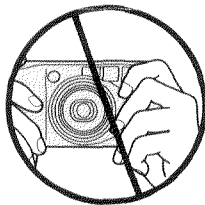

The green lamp blinks quickly and the shutter locks when you are too close to the subject. Make sure that you are at least 0.6m (2.0 ft.) from your subject.

- If you are closer than 0.4m (1.3 ft.), the green lamp will glow, but the picture will not be in focus.

- When your subject is closer than 1.0m (3.3ft.) at 38-60mm or 1.6m (5.2 ft.) at 65-105mm, compose your picture within the close-framing guides.

The green lamp blinks slowly when the subject contrast is low and the focus may not be accurate. Use focus hold and take the picture. (See "FOCUS HOLD" section.)

- The shutter can be released even if the green lamp blinks slowly; however, the focus will be set as follows:

With flash	_____	2.8m (9.2 ft.)
Without flash	_____	infinity

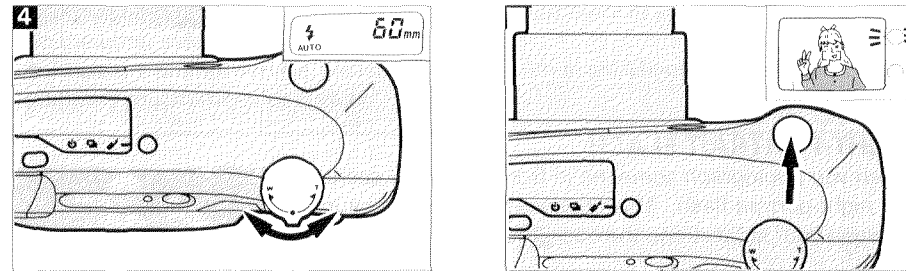
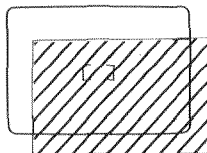

- 4** To zoom the lens toward wide (38mm), move the zoom control to the left. To zoom toward telephoto (105mm), move the control to the right. The focal length will appear in the camera display.

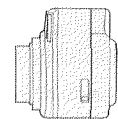

38mm

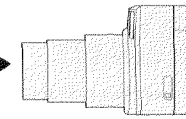

105mm

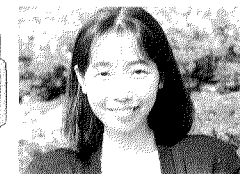

- 5** Press the shutter-release button partway down so that the focus lamp glows and then all-the-way down to take the picture.

In low-light conditions, the AF illuminator lights automatically.

Always press the shutter-release button with a slow, steady squeeze--never a quick jab.

The film automatically advances to the next frame.

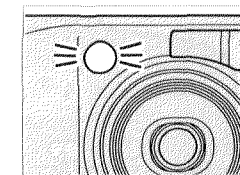

Caution: Do not hold the lens barrel while you photograph, otherwise focus may not be accurate.

FILM REWIND

AUTOMATIC REWIND



After you take the last picture on the roll, the camera automatically begins rewind and the frame counter counts down to 0.

When 0 appears in the data panel and the film-cartridge mark blinks, open the back cover and remove the film.

CAUTION

If 0 doesn't appear in the data panel after the motor stops running, check the display for the low-battery symbol. If it appears by itself, replace the battery and press the manual rewind button.

MANUAL REWIND

If you don't want to take the whole roll of pictures, you can begin film-rewind manually.

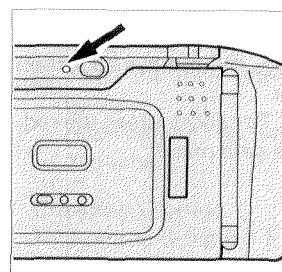

1. Turn the camera on and press the manual-rewind button using a pen or similar object.
2. When 0 and the blinking film-cartridge mark appear in the data panel, open the back and take out the film.

FOCUS HOLD

If you want to take a picture with the main subject placed to one side, use focus hold to ensure accurate focusing. You should also use focus hold in the special situations described here.

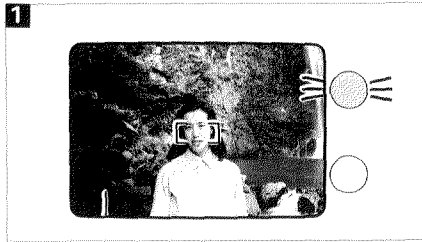

Off-center Subjects

- 1 Center the focus frame on your subject, then press and hold the shutter-release button partway down so that the green focus lamp glows.
- 2 Without lifting your finger, recompose the frame and press the shutter-release button all-the-way down to take the picture.

Special Focusing Situations

Some subjects or scenes, such as those described below, are difficult for the autofocus system to detect. To ensure proper focus in these situations, first lock focus on another object at the same distance from you as your main subject, then recompose your picture and press the shutter release.

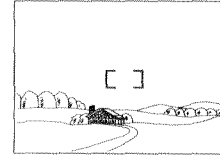

When a very bright or low-contrast area fills the center of the viewfinder.



When your subject is near a very bright object or area.

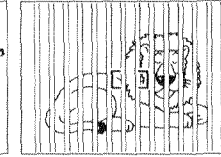

When two subjects overlap.

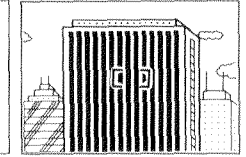

When a subject composed of alternating light and dark lines fills the center of the viewfinder.

- The green lamp will blink slowly to warn you that focus may not be accurate.

- The focus lamp may glow, but focus may not be correct.

- The green lamp will glow and the closer the two subjects will be in focus.

- The green lamp will blink rapidly and the shutter will lock.

FLASH

FLASH-MODE BUTTON

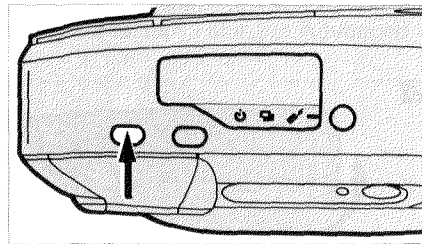

Pressing the flash-mode button changes the flash modes in the order shown in the table.

	Flash Mode	When to Use
	Auto-Switchover Flash	In all situations, except those listed below
	Manual Fill-Flash	When there are strong shadows on your subject's face.
	Flash Cancel	With twilight scenes and inside museums
	Night-Portrait Flash	When your subject is placed in front of a night scene

The indicator of the flash mode you select will appear in the data panel. Flash modes remain selected after you take the picture.

AUTO-SWITCHOVER FLASH

When you turn the camera on, auto-switchover flash is initially set. In this mode, the camera automatically fires the flash whenever necessary.

MANUAL FILL-FLASH

Use manual fill-flash to "fill-in" strong shadows on your subject's face. For example, manual fill-flash should be used when your subject is wearing a hat under bright sunlight. The flash will fire every time you take a picture.



FLASH CANCEL

When you're photographing twilight scenes or distant subjects that are beyond the flash range, cancel the flash.

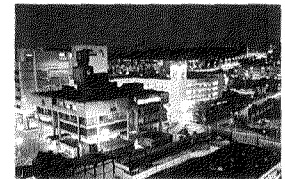

When the orange flash lamp blinks slowly shutter speeds will be slow. To avoid excessive blur in your pictures, use a tripod.

NIGHT-PORTRAIT FLASH

When you photograph someone in front of a night scene, use night-portrait flash. This provides balanced exposure between your subject and the background.



Shutter speeds are slow in this mode. Please use a tripod and warn your subject to remain still.

RED-EYE REDUCTION

Avoid red-eye in flash pictures of people by using red-eye reduction.

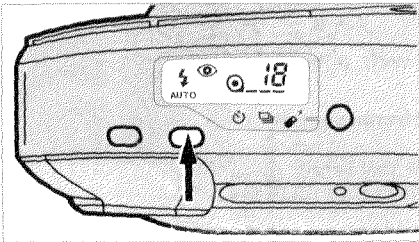

Press the red-eye-reduction button so that  appears in the data panel.

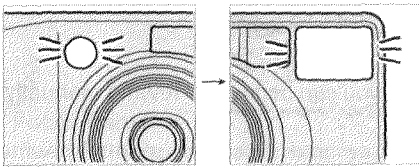

Warn the people you are photographing that the red-eye-reduction lamp will blink three times before the flash fires.

When you press the shutter-release button all-the-way down, the red-eye-reduction lamp blinks, then the main flash fires with the shutter release.

Red-eye-reduction mode remains selected until you cancel it. To cancel, press the red-eye-reduction button so that the indicator disappears from the data panel.

POINTS TO REMEMBER WHEN TAKING FLASH PICTURES:

1. FLASH LAMP

When the orange flash lamp blinks quickly, the flash is charging. Wait until it glows steadily and then take the picture. The flash takes approximately 3 seconds to charge.

2. FLASH RANGE

Make sure your subject is positioned within the flash range.

Flash Range		
	ISO 100	ISO 400
38mm	0.6m to 5.5m (2.0ft. to 18ft.)	0.6m to 11m (2.0ft. to 36ft.)
105mm	0.6m to 2.8m (2.0ft. to 9.2ft.)	0.6m to 5.6m (2.0ft. to 18ft.)

OPERATING-MODE BUTTON

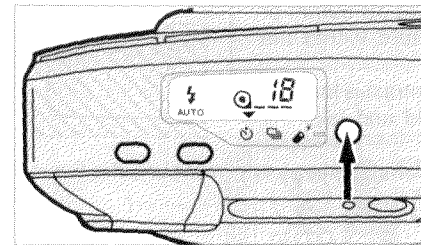

Each time you press the operating-mode button, the mode changes as shown in the table below.

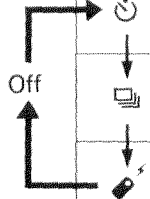
Operating Mode		When to Use
	Self-Timer	To include yourself in group pictures
	Continuous Drive	With action photography for sequence shots
	Remote Control	For releasing the shutter by remote control

• The mode pointer appears in the data panel next to the mark of the selected mode. If no mode is selected, no mark will appear.

• The optional accessory IR Remote Control RC-3 is required for you to use remote-control mode. Please refer to the RC-3's instruction manual for details.

SELF-TIMER

You can include yourself in the picture by selecting self-timer.

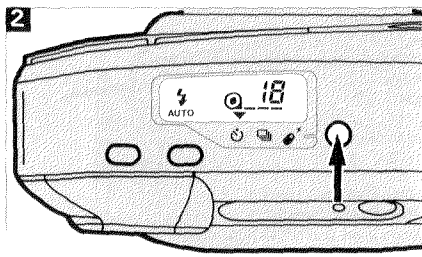

- 1 Set up the picture.
- 2 Press the operating-mode button until the mode pointer appears in the data panel above the self-timer mark.
- 3 When you're ready to take the picture, press the shutter-release button all-the-way down.
 - The mode pointer and the red-eye reduction lamp blinks to show that self timer is operating. There is a 10 sec. delay before the picture is taken.
 - Self-timer mode is canceled after the picture is taken. To stop self-timer operation before the picture is taken, turn off the camera.
 - To prevent light from entering the eyepiece and effecting the meter reading, make sure you are looking through the viewfinder when you press the shutter release.

CONTINUOUS-DRIVE MODE

When you're photographing moving subjects, take a sequence of shots.

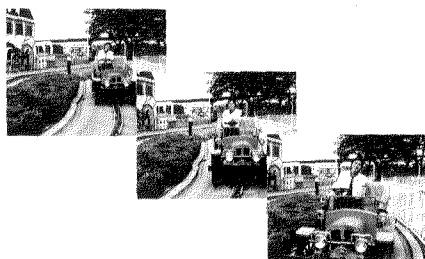
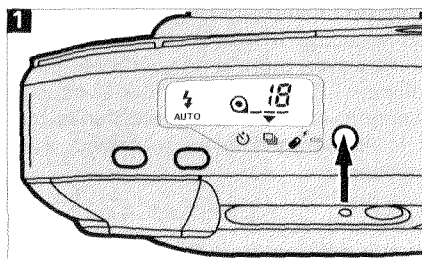

- 1 Press the operating-mode button until the mode pointer appears in the data panel above the continuous-drive mark.
- 2 When you're ready to take pictures, press the shutter-release button all-the-way down and hold.

The shutter will continue to release as long as the shutter-release button is held down. When taking flash pictures, the shutter will release after the flash has charged.

To cancel continuous-drive mode, press the operating mode button or turn the camera off.

TECHNICAL DETAILS

Lens: 38-105mm f/3.5-9.2 power zoom lens; 4 elements in 4 groups; max. magnification: approx. 1/5X (for subjects at 0.6m/2.0 ft. with 105mm lens)

Metering Range (ISO 100): 38mm: EV2.3 to EV17; 105mm: EV5.1 to EV17; in flash-cancel and night-portrait modes, shutter speed is set to 2.4 sec.

Battery Performance: Approximately 25 rolls (based on Minolta's standard test method using 24 exposure film with flash 50% of exposures)

Viewfinder

Magnification: 38mm: 0.42x; 105mm: 1.04x

Image Area: 85% coverage (for subject at 3m/9.8 ft.)

Dimensions: Standard model: 129.5(W) x 66(H) x 41mm(D)* (5.1 x 2.6 x 1.6 in.)

*44mm (1.7 in.) from grip

DATE model: 129.5(W) x 66(H) x 45mm(D)* (5.1 x 2.6 x 1.8 in.)

*48mm (1.9 in.) from grip

Weight (without batteries): Standard model: 260g (9.2 oz.)

DATE model: 270g (9.5 oz.)

Specifications are based on the latest information available at the time of printing and are subject to change without notice.

CARING FOR YOUR CAMERA

Cleaning

- If the lens becomes dirty, clean it gently with a lens brush. If necessary, moisten a sheet of lens tissue with one drop of lens-cleaning fluid and gently wipe the lens. Never touch the lens surface with your fingers.
- Never use alcohol or chemical solvents on the camera body. If it is dirty, wipe it gently with a soft, clean, dry cloth.

Precautions

- Use extra care when taking pictures at the beach. Do not let the camera get wet and do not let sand or other grit get into the camera. This could result in costly or irreparable damage to the camera.
- This camera is designed for use between -10 and 40°C (14 to 104°F).
- Never subject the camera to shock, high heat, or humidity.
- Never push or pull on the lens barrel — this could result in damage.
- Using the camera at very low temperatures impairs its performance. In cold weather, carry the camera inside your coat to keep it warm. Do not transfer the camera directly from an extremely cold to a warm area, since condensation may form inside and prevent normal operation.
- This camera contains high-voltage circuits. Do not attempt to disassemble or repair it yourself.

Storage

- When not in use, keep the camera in a cool, dry place away from dust and chemicals. For extended storage we recommend that you remove the batteries and place the camera in an airtight container with a drying agent such as silica gel.
- Do not store your camera in the glove compartment or other places in motor vehicles where it may be subjected to high temperatures.

Questions and Service

- If you have questions about your camera, contact your local camera dealer. For more information write to the Minolta distributor or subsidiary in your area (addresses listed on the other side of this manual).
- To assure prompt service, please contact an authorized Minolta Service Center before shipping your camera for repairs.

FOR OWNERS OF THE DATE MODEL

The data back enables you to record the date, in a choice of three formats, or the time directly onto the film. It features a quartz clock and automatic calendar through the year 2019 and automatically controls the imprint exposure according to the camera's film-speed setting. With the camera held horizontally, the data is recorded onto the lower right portion of the picture; in the vertical format, imprinting occurs on the lower left portion of the picture.



Names of Parts

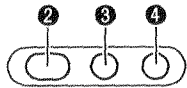

MODE SELECT ADJUST

- ① Print indicator
- ② MODE button
- ③ SELECT button
- ④ ADJUST button

Mode Selection

Use the MODE button to change the data display as shown.

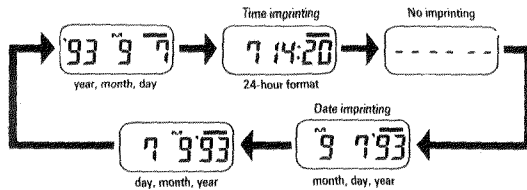

Data Imprinting

Press the MODE button to select the desired data type, then take the picture. Following exposure, the print indicator blinks in the data panel for approximately two seconds to confirm imprinting.

- The imprinted data may be difficult to read if the subject area over which it is superimposed is bright or non-uniform.
- Legibility of the imprinted data may vary somewhat with film type.

Setting Data

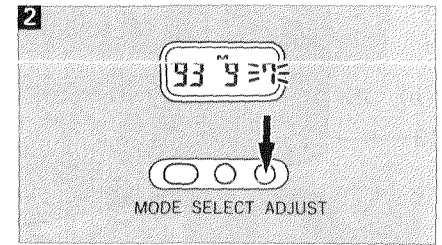
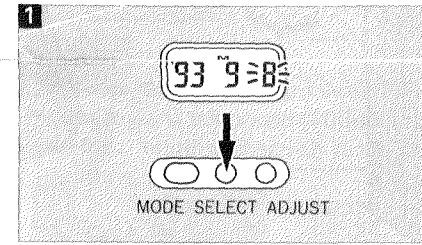

- 1** Use the SELECT button to choose the part of the display you want to change. With the date displayed, pressing the SELECT button in succession causes the settings for year, month, and then day to blink. In time mode, pressing the SELECT button successively causes the hour, minute, and then the colon to blink.
- 2** Press the ADJUST button to change the blinking display. In time mode, pressing the ADJUST button while the colon is blinking re-sets the seconds counter to 00.

Battery Replacement

The quartz data back uses a 3V lithium battery (CR1220).

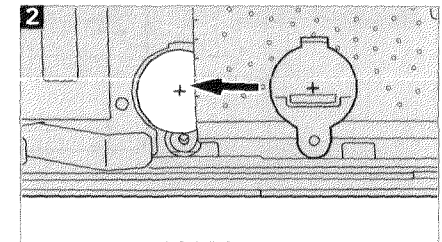
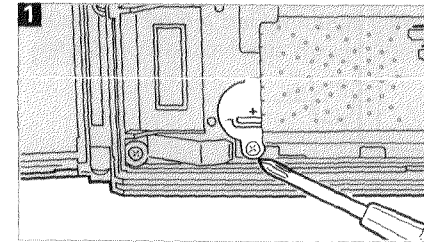

- 1** Open the camera back. Remove the screw from the battery cover using a small Phillips screwdriver.
- 2** Insert the new battery (+ side up). Replace the battery cover and attach with the screw. After battery replacement, follow the instructions under **Setting data** to reset day and time.

Care and Storage

This unit is designed for use between 40 and 0°C (104 and 32°F). At temperatures above or below this range, LCD and imprinted date may become difficult to read. Even higher temperatures may cause the LCD to temporarily blacken.